

This microprocessor controlled 20 output channels radio receiver is designed to operate with large number of hopping code transmitters in wireless alarms and access control systems. It features **KEELOQ®** code hopping transmitter verification system allowing highest level of security. The receiver provides 20 galvanic separated NC/NO relay outputs, each with front panel LED indication. Other features include transmitter's low battery warning indication and, in operation with selected transmitters, radio communication failure and transmitter's case opening sabotage protection signaling. The CH20H receiver operates with all Elmes Electronic made 434MHz band transmitters.

Each receiver channel may have pre-programmed any number of Elmes transmitters with total number operating with one CH20H receiver not exceeding 60. Next transmitter learned will delete the first in receiver's memory. Multi channel hand transmitters and RP501 transmitter learned to the receiver always control consecutive adjacent channels. Wireless detectors PTX50, GBX1 and CTX4H operate in two output channels of the receiver: motion alarm detection signaled in any channel 1...20 while sabotage alarm (TAMPER) signaled in channel 20 assigned automatically. Typical application fields of CH20H receiver include:

- **interfacing to any wired control panel** Elmes made wireless detector transmitters such as CTX, GBX, PTX and RP501 as well as key-fob transmitters (e.g. UMB100H) for system remote arming and disarming.
- **designing an alert call-in system or wireless panic button** – where personnel equipped with hand transmitters (e.g. AN200H or UMB100H) can actuate a call-in request or actuate panic alarm calling for help.

Receiver's outputs operation modes.

Actuating transmitter programmed to the receiver results in setting its channel relay output ON and illuminating channel's LED indicator. Output relays' SET ON timing depends on one of three operation modes described below, individually programmed to each output channel of the receiver.

1. **Temporary (pulse) set on mode** lasting from 0.5s up to 4h. Signal output S generates two pulses on any relay set and one pulse on reset (see programming pt.2).
2. **Latching on/off (bistable) mode** actuated by consecutive signals received from transmitter. Signal output S operates as above.
3. **Temporary (pulse) set on mode** lasting until **reset** is made by pressing the front panel LOW BATTERY CH. button (elsewhere referred to as BAT switch). For as long as output relay is set on signal output S generates pulses lasting 0,5s every 0,5s interval. Pressing the BAT switch resets relay output and stops signaling at output S. This operation mode enables designing an alert or intervention call system with call clearance made up by personnel authorized to use BAT button of the receiver. To enable this mode jumper JP4 of the receiver must be set OFF (see description of jumpers).

IMPORTANT! When operating with the RP501 transmitter in radio relay mode as well as with wireless detectors CTX3H or CTX4H respective output channel/s operating mode should be set to that described in pt.1 above. Despite pulse time mode, output's set on timing will match that of the transmitter.

Low Battery Warning.

Detected low battery in transmitter operating with CH20H receiver is warned by blinking front panel LED marked **LOW BATTERY INDIC.** and, if jumper **JP2** is set OFF (see jumpers description), setting on output **S**. To find out the output channel with low battery transmitter, illuminated button marked **LOW BATTERY CH.** must be pressed and low battery channel/s LEDs will illuminate. After replacing battery the failure indication sets off.

Communication with Detector Failure Warning.

CH20H receiver features detection of radio communication failures with wireless detectors **PTX, GBX & CTX4H.** The detectors send supervisory transmission every 10 hours. If, within 24 hours period, any transmission is not received from wireless detector, e.g. due to its technical failure, the receiver indicates that by pulsing **LOW BATTERY INDIC.** similar as low battery warning. However, when **LOW BATTERY CH** button is pressed, relays and LEDs in channels with communication failure will start pulsing as contrary to steady LED light on in the case of low battery indication. Any radio transmission received from detector with communication failure clears the failure warning. To actuate communication failure warning function **JP3** should be set OFF after completing installation and learning all detectors. Similarly, every change in wireless detectors' configuration with the receiver (deleting detector or moving detector to other channel) requires **JP3** to be set ON for a while and then OFF, followed by detectors actuation in order to initialize the function.

IMPORTANT! Proper functioning of channel low battery and radio communication failure warnings require that only one wireless detector operates in the channel.

Radio Jamming Sabotage Warning.

CH20H receiver features function of detecting deliberate or incidental radio jamming in its operating band. This anti-sabotage function is active when **JP5** is set OFF. Detected sabotage jamming is warned by momentary setting ON receiver relay output 19.

Jumpers description.

- JP1** - set ON – output S generates pulses on any output channel set on and off;
set OFF – output S generates pulses on channel 1 output set on and off only;
- JP2** – set ON – output S signals channel set on and off – see outputs operating modes and description of JP1 above;
set OFF – output S signals low battery in transmitter and, if JP3 is set OFF, communication failure;
- JP3** – set ON – radio communication supervision with wireless detectors set OFF;
set OFF – radio communication supervision with wireless detectors set ON;
- JP4** – set ON – selects standard operating mode with outputs in pulse or latched mode as in pts. 1&2 above;
set OFF – receiver in call-in operating mode as described in pt.3 of outputs operating modes;
- JP5** – set ON – radio jamming detection function set OFF;
set OFF – radio jamming detection function set ON.

Installation and Outputs Settings.

Receiver CH20H operates indoors with ambient temperature range 0 to +40°C. Installation place should be dry, possibly high and far from electromagnetic power lines, radio transmitters, metal screening and devices that may cause interference reducing operation range. Wire antenna should be let loose downwards and cannot be glued to wall. Practical tests should be taken prior to firm installation of receiver and transmitters to determine exact operation range. Factory outputs setting is **NC** (normally closed). Setting relay outputs to **NO** is made by solder joints made for each relay on pc board soldering side. Disconnecting receiver's power supply or opening its case sets off output channel 20 indicating sabotage alarm (TAMPER).

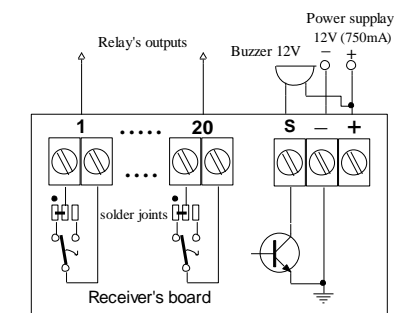

CH20H wiring diagram

PROGRAMMING PROCEDURES

Programming is performed with front panel taken off and the use of programming switches PRG (small switch with PRG marked on pcb) and BAT (front panel illuminated switch marked LOW BATTERY CH.). Programming stages are indicated by red LED in middle-top section of the receiver.

1. **Learning transmitter(s) (wireless detectors or keyfobs) to receiver's memory (maximum 60) follow steps as below:**
 - a) Press shortly receiver's PRG switch. The PRG LED switches off and on and the first channel indication LED illuminates.
 - b) By shortly pressing the PRG switch select the required channel for learning transmitter.
 - c) Shortly press the BAT switch – the LED will switch off,
 - d) Depending on type of programmed transmitter proceed with next step as follows:
 - hand transmitters (keyfobs) – double press the transmitter's button (as in example 1) respective to required control channels.
 - PTX50 detector (in **TEST** mode) – actuate two transmissions by moving hand in front of the detector (as in example 2).
 - CTX3H, CTX4H wireless detectors – actuate two transmissions by double moving magnet in and out of case reed relay side or opening door/window if installed.
 - RP501 transmitter - set the required mode of operation in transmitter (radio link testing mode not allowed), couple all inputs to ground and actuate transmission

by decoupling one of the inputs (as in example 3) respective to required control channels.

e) Blinking LED in the receiver will indicate end of the procedure.

Examples:

1. Learning control button 4 (green) of four channel keyfob transmitter CH4H to output channel 8 of CH20H receiver would automatically learn the remaining keyfob control buttons 1, 2 & 3 to channels 5, 6 & 7 of the receiver.
2. Learning wireless motion detector PTX50 to output channel 3 of CH20H receiver results by motion detection signaled in channel 3 while detector's sabotage case opening signaled in channel 20.
3. Learning transmitter RP501 inputs 1 & 2 to CH20H receiver output channels 11 & 12 respectively, output channel 12 should be selected (as in pt. 1b above) in the receiver and input 2 of the transmitter should be actuated (decoupled). As result inputs 1 & 2 of RP501 transmitter would control outputs 11 & 12 of CH20H receiver. Inputs 3 & 4 of the transmitter are not used.

2. Programming receiver's any output channel/s momentary set on time (monosable mode).

- a) Press & hold receiver's PRG switch (longer than 2 and less than 8 seconds) until LED sets on.
- b) Shortly pressing the PRG switch select required channel for programming momentary output's set on time.
- c) Shortly press the BAT switch and the LED sets off.
- d) Shortly press PRG switch again, the LED sets on and the count of output momentary set on time starts. When desired set on time has lapsed (up to 4 hours) press the PRG switch again. End of correctly performed procedure is indicated by blinking LED.

3. Programming receiver's any output channel/s on/off operating mode (latched - bistable mode).

- a) Repeat programming steps 2a, 2b & 2c as above.
- b) Shortly press PRG switch three times with less than two seconds intervals. End of correctly performed procedure is indicated by blinking LED.

4. Deleting all transmitters from receiver's memory.

Press receiver's PRG switch until programming LED starts blinking (longer than 8 seconds) and then release the switch. Receiver's memory is cleared but the output channels' programmed modes of operation remain unchanged. To learn new transmitter(s) follow procedure pt. 1 above.

5. Deleting single transmitter from receiver's memory.

Except for RP501 transmitter, it is possible to delete any other single transmitter (keyfob or wireless detector) from receiver's memory under condition that the transmitter to be deleted is in our possession. This procedure requires performing steps a, b & c of learning procedure pt.1 above, with two succeeding transmissions at step 1.d to be performed in the following way: first transmission must be sent from the transmitter to be deleted and second transmission from any other transmitter (e.g. by pressing other button in multi channel hand held transmitters). Receiver's LED blinking red will indicate programming error – in this case meaning that the transmitter is deleted. The receiver will not response any more to signals sent from deleted transmitter.

NOTE: programming errors are indicated by fast blinking PRG LED. If no programming steps are made for more than 16s, the receiver sets off programming mode.

Specification

- power supply 11 to 15VDC (nominal 12VDC); 35mA current plus 23mA on every relay set on, 500mA maximum.
- 20 channel relay NC or NO outputs rated 1A/24VDC or 0,5A/125VDC with LED indication; one open collector type output "S" rated 1A/60VDC max.,
- super heterodyne 433,92MHz band receiver with up to 60 code hopping transmitters (wireless detectors and keyfobs) memory and open case switch (TAMPER),
- strictly indoor installation, operation within ambient temperatures 0 to +40 °C and range depending on installation environment and type of transmitter.

Manufacturer: *ELMES ELECTRONIC, 54-611 Wrocław, ul. Avicenny 2, tel. (071) 784-59-61, fax (071) 784-59-63*

Manufacturer's Limited Warranty

This product carries two years manufacturer's warranty as from the date of purchase. The warranty is limited to the replacement of faulty original parts or repair defects of improper manufacture. Damage, faulty use or improper handling by the user or installer as well as any changes in product's hardware or software caused by the user violets the warranty and all due repair costs will be charged. Elmes Electronic shall not bear liability for any personal or material damage resulting from any of its products direct, indirect or partial failure to operate properly.

Confirmed date and place of product purchase

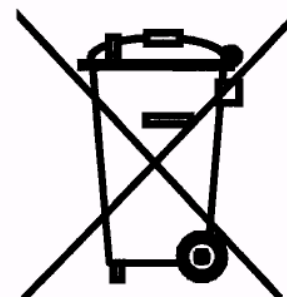

CE

Conformity Declaration

Product: **CH20H - Twenty Output Channels Receiver.**

The product is dedicated to use in electronic alarms and security systems and operates in radio frequency band of 433,92 MHz.

The product is manufactured in compliance with EU Directive: **R&TTE 1999/5/EC**

In particular, the product complies with the following harmonized standards:

EN 300 220-3: EMC and Radio Spectrum Matters.

EN 301 489-1: EMC for Radio Equipment.

EN 60950-1:2001 Electric Safety.

Manufacturer: Elmes Electronic, ul.Avicenny 2, 54-611 Wrocław, Poland

Date of Signature: 31.07.2008

Director: *Mirosław Bińkowski* Signature:

IMPORTANT! The use of above symbol indicates that this product should not be treated as household waste. By ensuring this product is disposed of correctly you will protect the environment. For detailed information about recycling of this product, please contact your local authority, your household waste disposal service provider or organization the product has been purchased from.